

STM Series Slide Bearing Cylinder



STMB 16 × 50



STMS 16 × 125

Ordering Code

STM

Series Code
Sliding Type

B

Mounting type
B: Body fixed Type
S: Sliding Block Fixed Type

16

×

50

Cylinder Bore
10mm
16mm
20mm
25mm

Stroke
0~250mm

Specification

Bore(mm)	10	16	20	25
Motion Pattern	Double action			
Working Medium	Air			
Operating Temperature Range	-5~+70℃			
Operating Pressure Range	1.0~9.0kgf/cm ²			
Ensured Pressure Resistance	13.5kgf/cm ²			
Operating Speed Range	50~200mm/s			
Buffer Type	Shock Absorter			
Lubrication	NO			
Non-rotating Precision	±0.1°		±0.05°	
Port size	M5×0.8			G1/8"

Standard Stroke

Bore size (mm)	Standard stroke (mm)									
10	25	50	75	100						
16	25	50	75	100	125	150	175	200		
20	25	50	75	100	125	150	175	200	250	
25	25	50	75	100	125	150	175	200	250	

Thoretical thrust

Bore size	Rod size (mm)	Pressure area (cm ²)	Operating pressure(Kgf/cm ²)								
			1	2	3	4	5	6	7	8	9
10mm	6	0.50	0.48	0.95	1.43	1.9	2.38	2.85	3.43	3.8	4.28
16mm	8	1.51	1.43	2.87	4.30	5.74	7.17	8.61	10.04	11.48	12.91
20mm	10	2.36	2.24	4.48	6.73	8.97	11.21	13.45	15.69	17.94	20.18
25mm	12	3.78	3.51	7.18	10.77	14.36	17.96	21.55	25.14	28.73	32.32

STM Series Slide Bearing Cylinder

Overall Dimensions

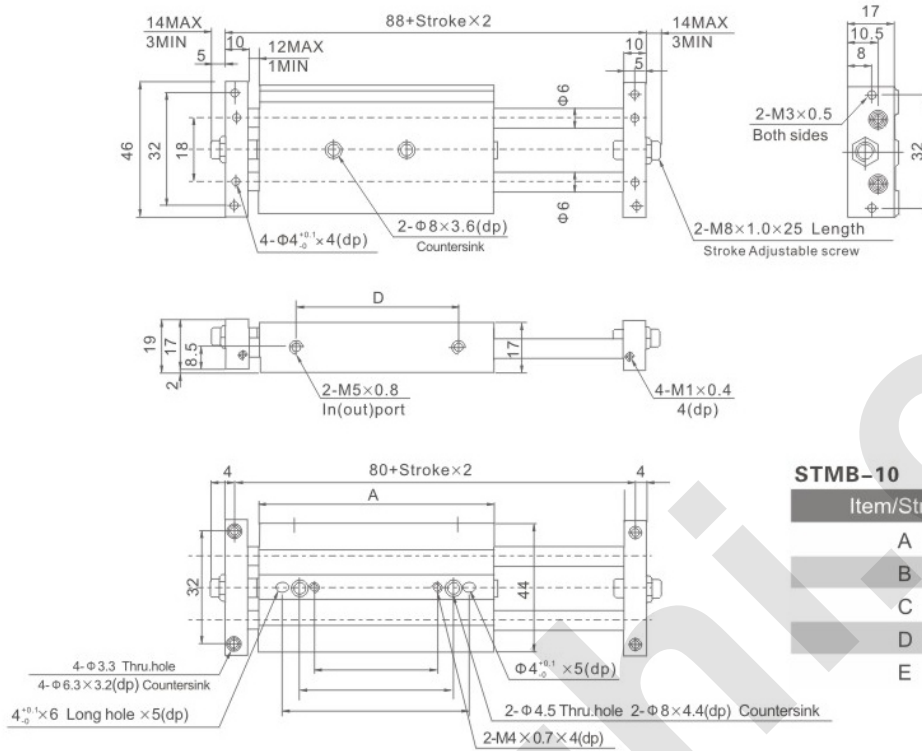

STMB-10

Item/Stroke	25	50	75	100
A	81	106	131	156
B	65	85	85	85
C	35	60	60	60
D	46	71	96	121
E	15	40	40	40

Overall Dimensions

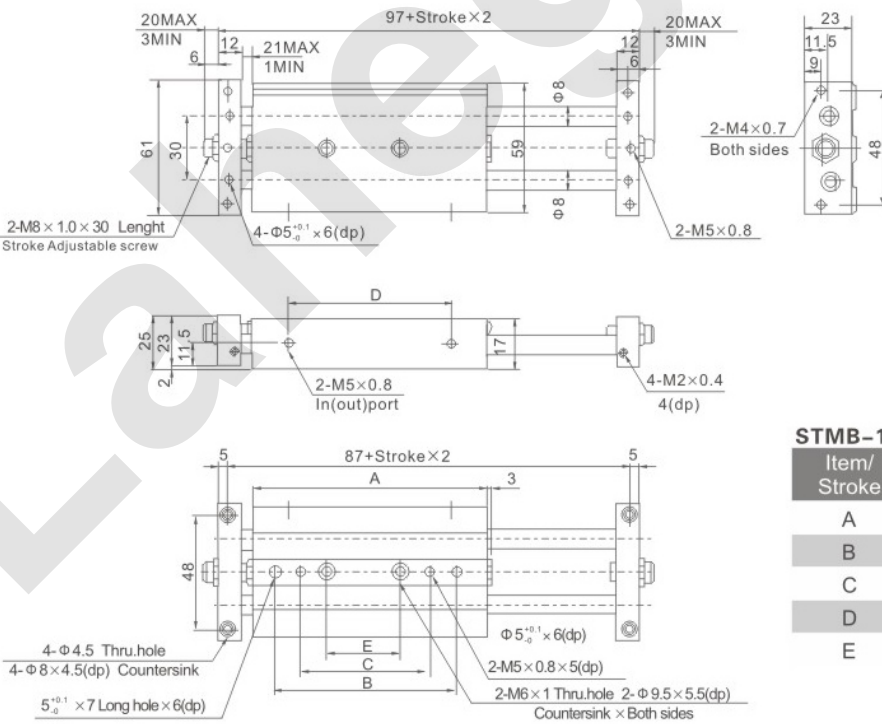

STMB-16

Item/Stroke	25	50	75	100	125	150	175	200
A	86	111	136	161	186	211	236	261
B	55	70	105	130	150	150	150	150
C	-	-	75	100	120	120	120	120
D	48	73	98	123	148	173	198	223
E	25	50	45	70	90	90	90	90

STM Series Slide Bearing Cylinder

Overall Dimensions

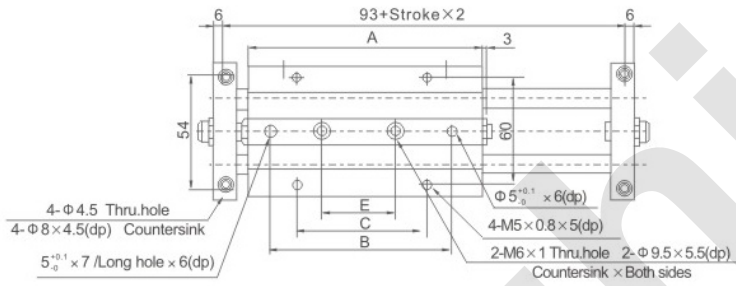
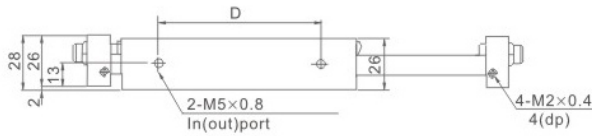
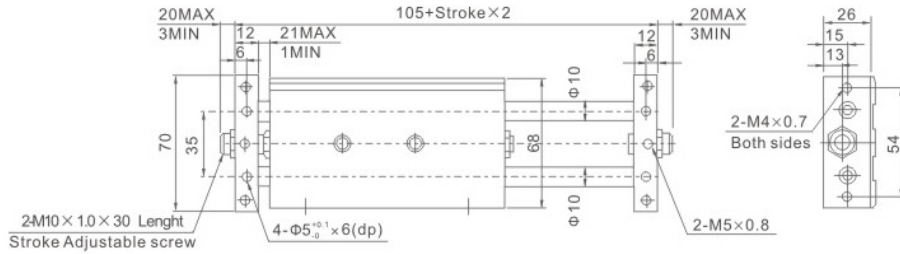

STMB-20

Item/ Stroke	25	50	75	100	125	150	175	200	250
A	94	119	144	169	194	219	244	269	319
B	60	85	110	135	150	150	150	150	150
C	50	50	75	100	120	120	120	120	120
D	53	78	103	128	153	178	203	228	278
E	35	45	45	70	90	90	90	90	90

Overall Dimensions

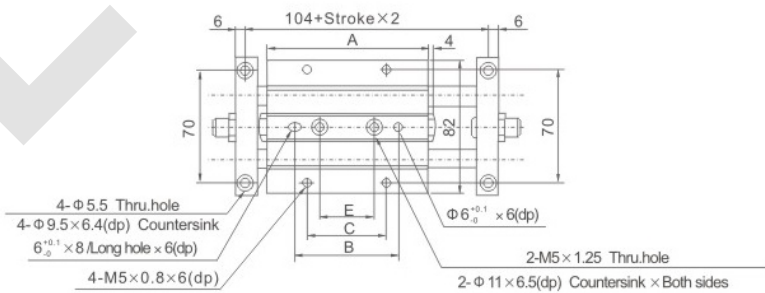
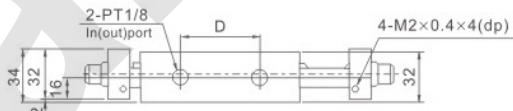
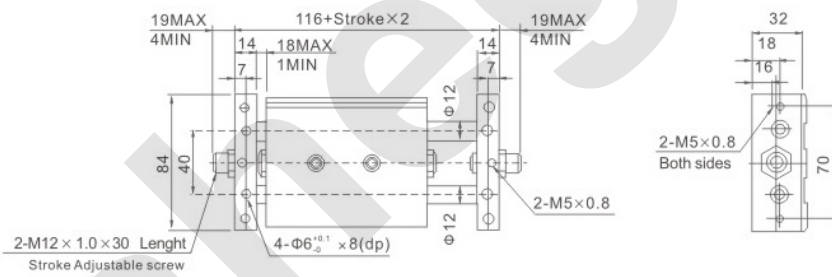

STMB-25

Item/ Stroke	25	50	75	100	125	150	175	200	250
A	101	126	151	176	201	226	251	276	326
B	65	90	115	140	140	140	140	140	140
C	50	50	75	100	100	100	100	100	100
D	50	75	100	125	150	175	200	225	175
E	35	45	45	70	95	100	100	100	100

STM Series Slide Bearing Cylinder

Overall Dimensions

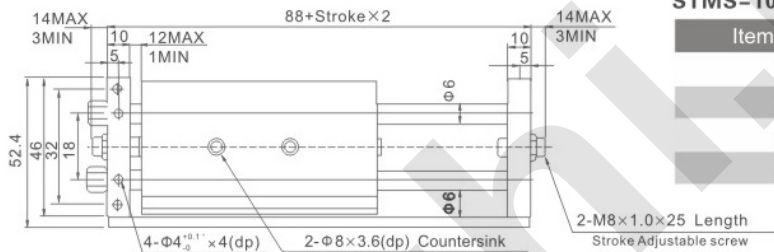
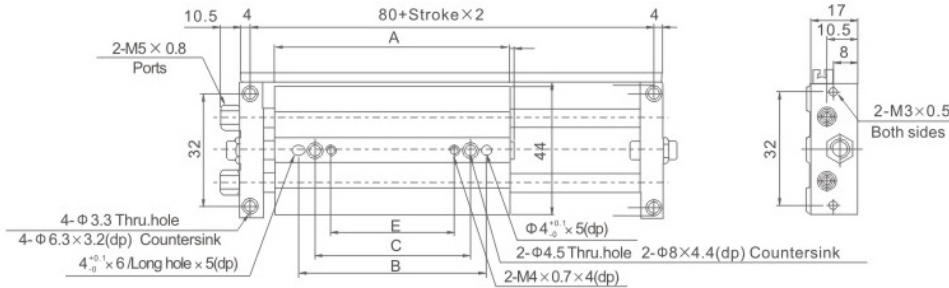

STMS-10

Item/Stroke	25	50	75	100
A	81	106	131	156
B	65	85	85	85
C	35	60	60	121
E	15	40	40	40

Overall Dimensions

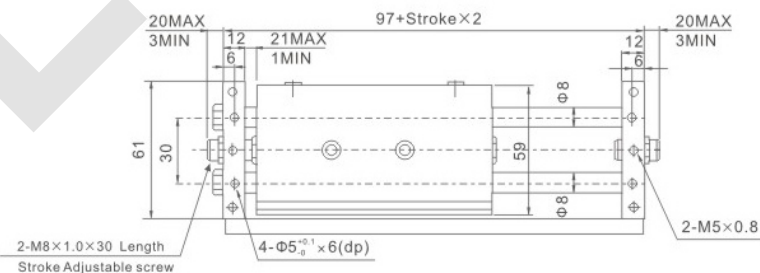
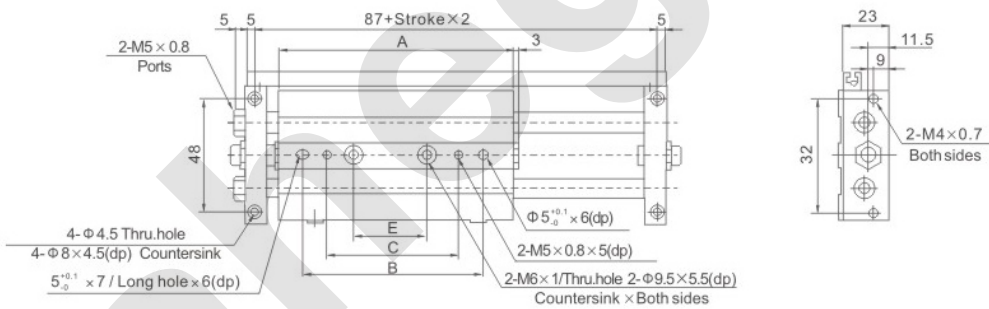

STMS-16

Item/Stroke	25	50	75	100	125	150	175	200
A	86	111	136	161	186	211	236	261
B	55	70	105	130	150	150	150	150
C	-	-	75	100	120	120	120	120
E	25	50	45	70	90	90	90	90

STM Series Slide Bearing Cylinder

Overall Dimensions

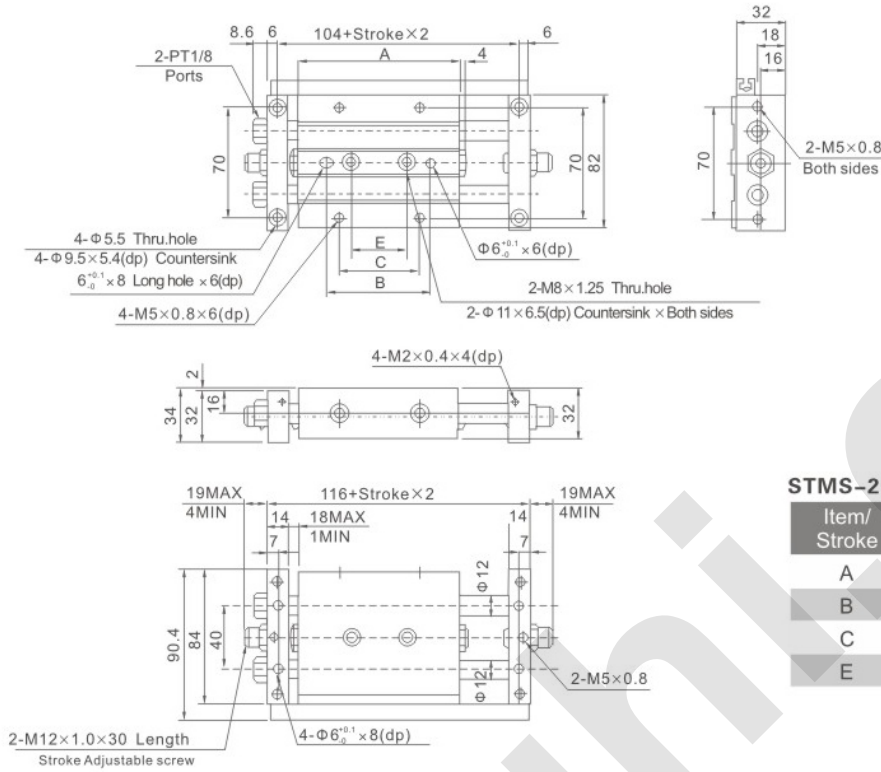

STMS-20

Item/ Stroke	25	50	75	100	125	150	175	200	250
A	94	119	144	169	194	219	244	269	319
B	60	85	110	135	150	150	150	150	150
C	50	50	75	100	120	120	120	120	120
E	35	45	45	70	90	90	90	90	90

Overall Dimensions

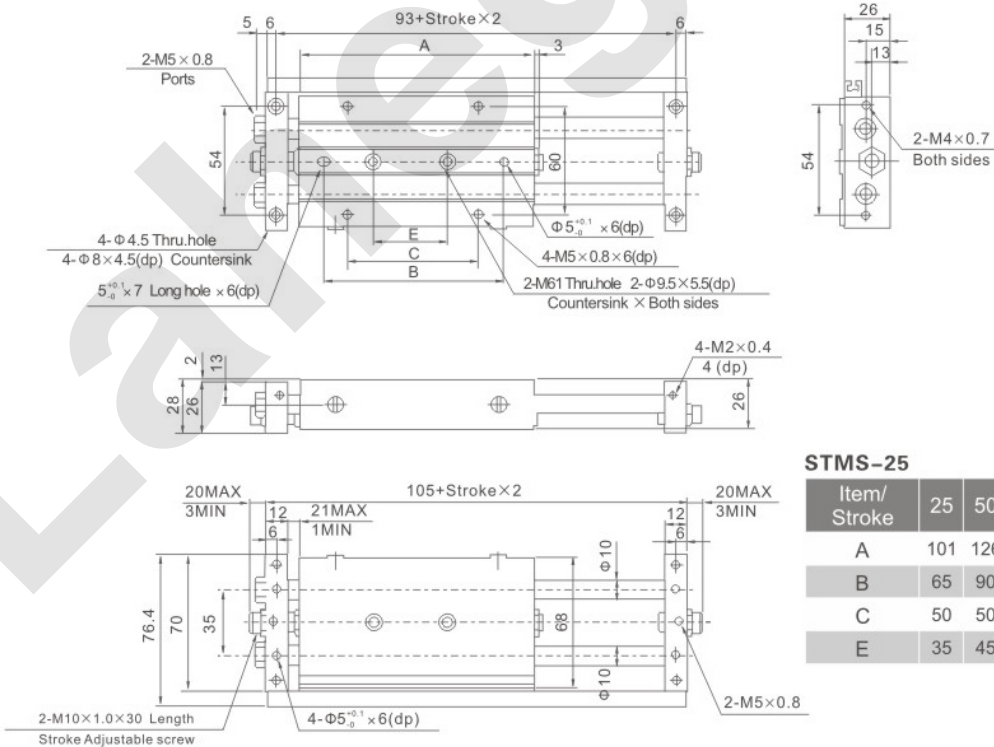

STMS-25

Item/ Stroke	25	50	75	100	125	150	175	200	250
A	101	126	151	176	201	226	251	276	326
B	65	90	115	140	140	140	140	140	140
C	50	50	75	100	100	100	100	100	100
E	35	45	45	70	95	100	100	100	100